

K.HARTWALL



LIFTLINER®



# LIFTLINER®

Our LiftLiner® product family is a compact tugger train solution for internal logistics and an excellent choice for reducing forklift traffic. Avoid the complexities of sequenced deliveries to maximize production flexibility.

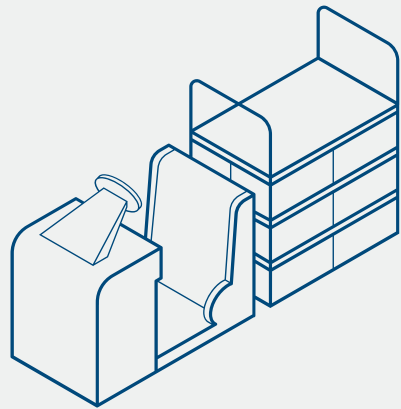



## WELCOME TO THE FAMILY

Increase efficiency,  
health & safety, and ergonomics through

- Compact train length
- Fully electric lifting and tilting technology
- Ergonomic loading and unloading from either side
- Tight steering angles
- Excellent tracking

# LOOK AT WHAT YOU CAN ACHIEVE WITH LIFTLINER®



Streamline operations to reduce forklift traffic



Improve the efficiency of an existing tugger train system



Improve ergonomics and health & safety



Find a solution to support a new production layout



Move to partial or fully automated operations



Reduce Total Cost of Ownership



## EFFICIENT MILKRUN OPERATION

Reduce forklift traffic



## LESS

- TRAFFIC
- ACCIDENTS
- PRODUCT DAMAGES



## FASTER

- TRANSPORTS
- LOAD HANDLING
- PRODUCTION LINE SUPPLY

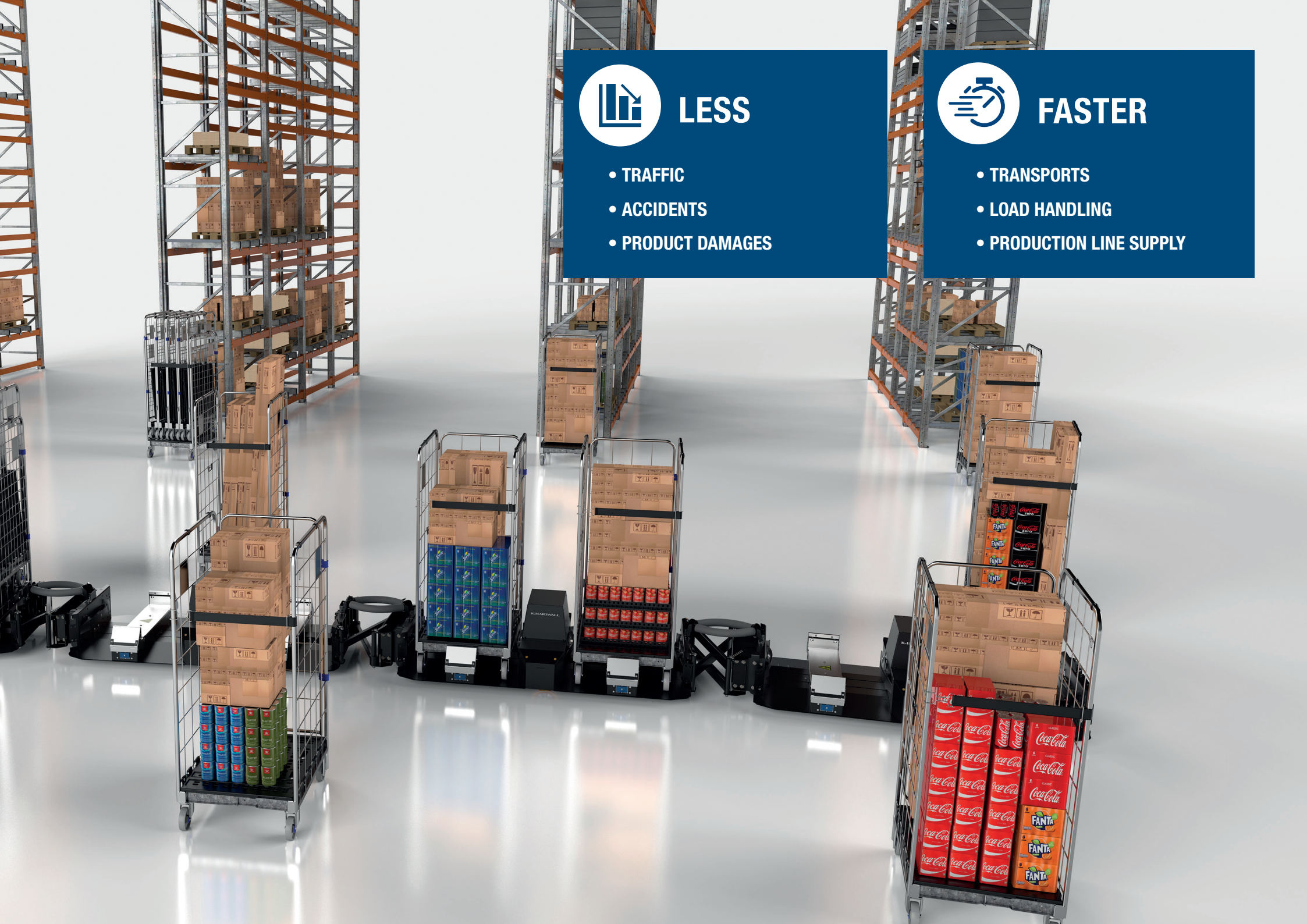

# LIFTLINER® TUGGER TRAINS

Flexible units for different loads and processes



- Transports multiple load carriers in various sizes on a single LiftLiner®
- Shortest trolley train on the market
- Most efficient deliveries to production lines

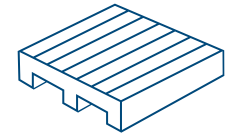

- First trolley train to transport a wide range of roll carts and dollies
- Extremely compact design
- Easy and streamlined fleet handling

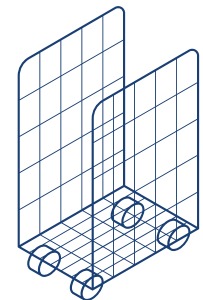

# INCREASE EFFICIENCY



## BUNDLE INDIVIDUAL TRANSPORTS ▶

Transports various load carriers in multiple sizes



## USE THE MOST ▲ EFFICIENT ROUTES

(Un-)loading from either side – no need for sequencing



## SAVE VALUABLE SPACE ▶

Extremely compact design tailored to the load dimensions

## ◀ SAVE TIME

Fast and fully electric lifting increases agility



# INCREASE HEALTH & SAFETY



## ENSURE SAFETY ▶

Train only moves when the carts are locked



## MINIMIZE HAZARDS ▲

Walk-through between carts is prevented by the crossbar coupling



## ◀ PREVENT BUCKING

Safe transport through an excellent tracking accuracy



## ◀ PREVENT INJURIES

Smooth rounded edges of the carts create a safe work environment

# INCREASE ERGONOMICS



## MAKE UNLOADING EASY ▶

Tilting technology eases  
load carrier handling

## SUPPORT THE OPERATOR ▼

Load carrier wheels turn automatically  
when tilting helping the operator unload



## HANDLE LOADS SAFELY ▲

Combination of innovative  
design and tilting technology



## ENSURE EFFORTLESS LOADING ▶

Rooftop shape of the carts balances  
forces to ease the (un-)loading



# SUCCESSFUL CUSTOMER PROJECTS

Transport of large non sortable parcels over long distances with LiftLiner® combined with K.Hartwall SmartCube® foldable cages that are placed on Daughter Carts.



posti

“With the LiftLiner®, we were able to improve our general safety by reducing unnecessary forklift traffic in our terminal, and at the same time, improve the efficiency of moving parcels internally. This is especially critical in our operations during peak hours and high seasons”, says Janne Mattila, Head of Sorting at Posti.

When planning the new plant for the production of electric motors, Parvalux decided to use both the LiftLiner® and load carriers from K.Hartwall for internal material transport.



parvalux  
by maxon

“By implementing a milk run with the LiftLiner® trolley train we were able to increase the efficiency of the picking process as well as the efficiency and reliability of our internal material transport” comments Paul Gilbert, Logistics Manager at Parvalux.

# WE ARE ALSO USING THE LIFTLINER® TUGGER TRAINS



BORGWARNER



EXPERIENCE. KNOWLEDGE. RELIABILITY.



K.Hartwall strives to create future fit supply chain solutions that answer the needs of our customers and bolsters their industry development.

Over the years, we have become specialized in innovative supply chain solutions for the Retail & Grocery, Parcel & E-Commerce, and Industrial Manufacturing industries.

**K.HARTWALL**

## K.Hartwall North America

49 North Paragon Drive  
Romeoville, IL 60446 USA  
info.usa@k-hartwall.com

### Follow us online



[www.k-hartwall.com](http://www.k-hartwall.com)

### Contact Our Team

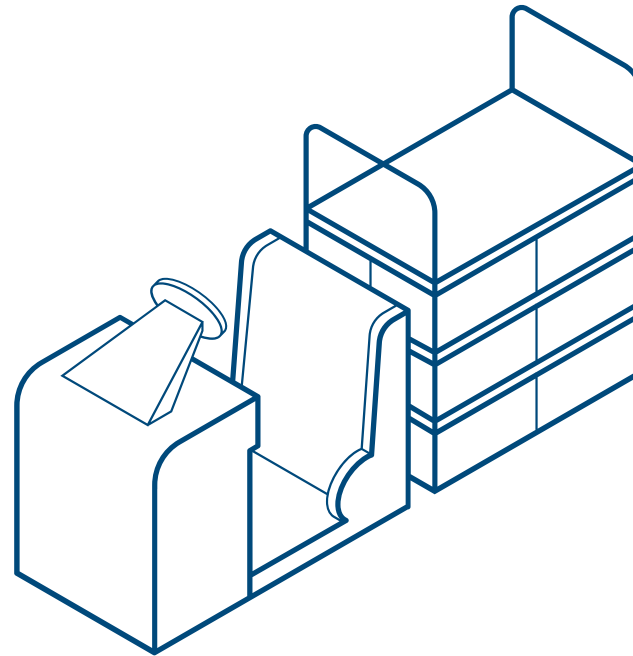

Watch Our  
LiftLiner®  
Video



Watch Our  
LiftLiner® RC  
Video

MAKE THE NEXT  
**SMART MOVE**  
IN SUPPLY CHAIN

